

**MOISTURE SEPERATOR**

**MOISTURE SEPERATOR STANDARD WITH**

SPECIAL FEATURES	OPTIONAL FEATURES	STD. WORKING PARAMETERS
<ul style="list-style-type: none"> <li>Wide range of 15 standard models with capacities from 50 m3/hr. To 6000 m3/hr.</li> <li>Higher capacities - available on request</li> <li>Compact design</li> <li>Moisture separator in accordance with international design code like- ASME , IS-2825</li> <li>Manual drain valve with moisture separator</li> <li>Duly tested - pneumatically &amp; hydrostatically</li> </ul>	<ul style="list-style-type: none"> <li>Auto drain valve</li> <li>Construction accordance to other various codes</li> <li>Demister pad type</li> <li>Cyclone type</li> </ul>	<ul style="list-style-type: none"> <li>Pressure :- upto 14 kg/cm2(g)</li> <li>Temperature :- 35°C</li> </ul>

**Specification Sheet for Moisture Separator**

MODEL NO.	CAPACITY IN M3/HR	DIMENSIONS ( IN MM )		CONNECTION (IN MM)
		D	H	N1 & N2
MS-50	50	100	475	15
MS-100	100	100	475	20
MS-250	250	100	475	32
MS-500	500	150	560	50
MS-750	750	150	625	50
MS-1000	1000	200	700	80
MS-1250	1250	200	750	80
MS-1500	1500	250	850	100
MS-1750	1750	250	900	100
MS-2000	2000	250	950	100
MS-2500	2500	300	1000	100
MS-3000	3000	300	1000	100
MS-3500	3500	350	1050	150
MS-4500	4500	350	1100	150
MS-6000	6000	400	1100	150

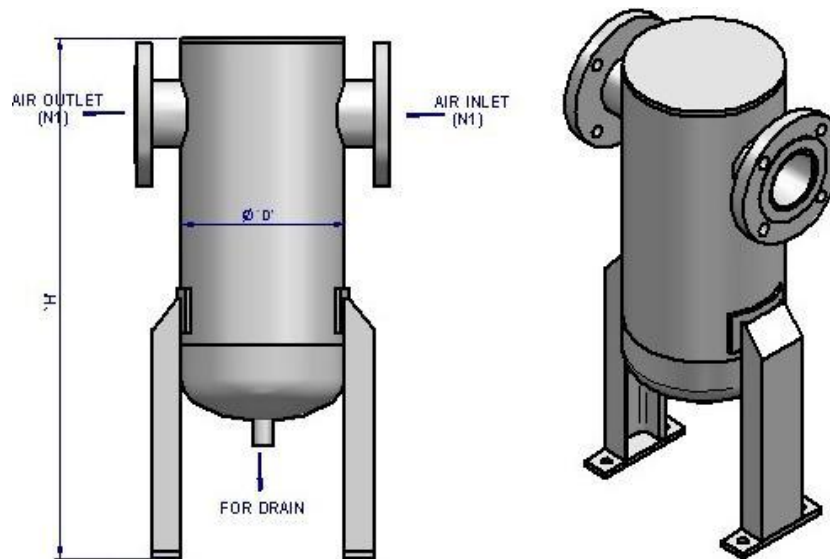

ALL DATA SUBJECT TO CHANGE WITHOUT NOTICE