

**HEATLESS DRYER
DC PLATINUM SERIES**

DC PLATINUM SERIES HEATLESS DRYER DRIED AIR CONTINUOUSLY COME STANDARD WITH

SPECIAL FEATURES	OPTIONAL FEATURES
Wide range of 14 standard models with capacities from 6 nm ³ /hr. to 1700 nm ³ /hr. Higher capacities are available on request Pressure dew point achievable (-) 40°C and below Electronic controls/solid state timers for automatic and reliable operation Low power consumption Equipped with muffler on purge air outlet to reduce noise level Specially graded desiccant <i>Delsorb</i> 10 for optimum performance and long life	Humidity indicator Smart display card (in DC-121 to 123) Filters and/or total dryer by pass line with valves. Special delair filters for removal of water, oil mists, oil vapour and dust particles with electronically operated drain valves Explosion proof controls for offshore application Construction according to various codes

Specification sheet for DC Platinum Series Heatless Dryer

MODEL No.	CAPACITY IN NM ³ /HR.							CONNECTION BSP FEMALE/ FLANGE (IN INCHES)	DIMENSIONS (IN MM)			WEIGHT (IN KG)
	PRESSURE IN BAR (G)								L	W	H	
	4	5	6	7	8	9	10					
DC 121	3.9	4.7	5.5	6.3	7.0	7.8	8.6	1/4 BSP	410	350	660	22
DC 122	7.8	9.4	10.9	12.5	14.1	15.6	17.2	1/4 BSP	420	350	700	25
DC 123	15.6	18.8	21.9	25.0	28.2	31.3	34.5	1/4 BSP	455	350	880	30
DC 124	34.2	41.0	47.9	54.7	61.5	68.4	75.4	1/2 BSP	590	420	1570	100
DC 125	45.7	54.8	63.9	73.0	82.2	91.3	100.5	1/2 BSP	590	420	2020	150
DC 126	68.4	82.0	95.7	109.5	123.0	136.8	150.5	3/4 F	755	700	2180	180
DC 127	103.0	123.0	144.0	164.0	185.0	205.0	226.0	1 F	820	750	2050	220
DC 128	182.0	219.0	255.0	291.0	328.0	365.0	401.0	1.1/2 F	1050	750	2200	260
DC 129	275.0	329.0	384.0	439.0	494.0	549.0	604.0	1.1/2 F	1105	850	2170	345
DC 130	398.0	478.0	557.0	637.0	717.0	796.0	876.0	2 F	1275	1500	2350	850
DC 131	524.0	629.0	734.0	839.0	944.0	1048.0	1153.0	2 F	1360	1500	2300	1100
DC 132	662.0	794.0	926.0	1058.0	1190.0	1323.0	1455.0	2 F	1410	1550	2270	1200
DC 133	844.5	1012.4	1181.5	1352.0	1518.5	1690.0	1858.2	2.1/2 F	1660	1650	2620	1250
DC 134	1055.6	1265.5	1476.5	1690.0	1898.2	2111.3	2322.7	3 F	1870	1750	2870	1500

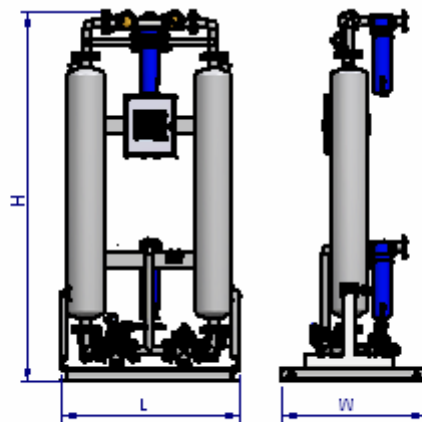

SKID MOUNTED

ALL DATA SUBJECT TO CHANGE WITHOUT NOTICE